

6-MSP SERIES

APPLICATIONS

- Ideal for general water transfer applications and household water removal in places like basements, crawl spaces, rooftops, and window wells

FEATURES

- Submersible 1/3HP utility pump
- Thermally protected motor
- Includes 3/4" GHT adapter
- Includes 1-1/4" FNPT adapter
- Corrosion-resistant epoxy-coated cast aluminum casing for superior heat dissipation
- Lightweight, portable with easy carry handle



SERIES SPECIFICATIONS

Volts	Hz	Amps	Watts	Performance (GPM / Liters per Minute @ Height)					Shut-Off	PSI Bar
				1 ft / 0.3 m	3 ft / 0.9 m	5 ft / 1.5 m	10 ft / 3 m	20 ft / 6.1 m		
115	60	3.5A	350	35.5 134	33 125	31 117	25 94.6	13 49.2	30 ft / 9.1 m	12.6 0.38

Item No.	Model	HP	Volts	Switch Type/ Operation	Cord	Weight
14942783	6-MSP	1/3	115	Manual	10' 3 m	8.8 lbs 4.0 kg

UTILITY PUMPS

6-MSP SERIES

PERFORMANCE DATA

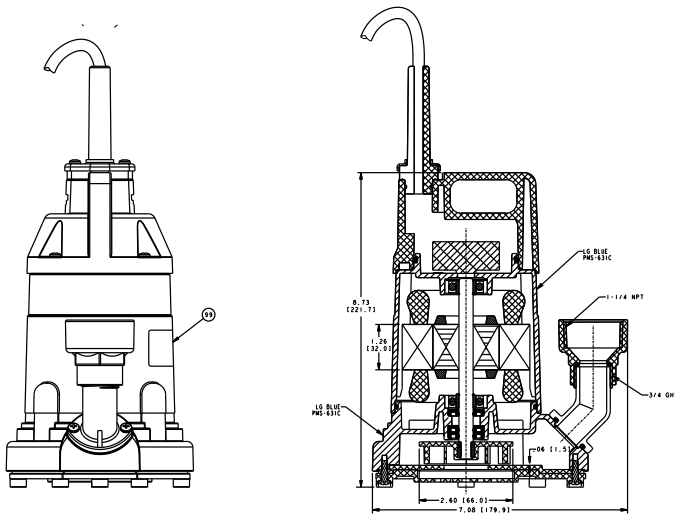

GPM	Head
36.5	0
35.5	1
31	5
25	10
20	15
13	20
5.5	25
0	29

LPM	M
138	0.00
134	0.30
117	1.52
95	3.05
76	4.57
49	6.10
21	7.62
0	8.84

PERFORMANCE DATA

Sump/Effluent Pump Composite Performance Curves

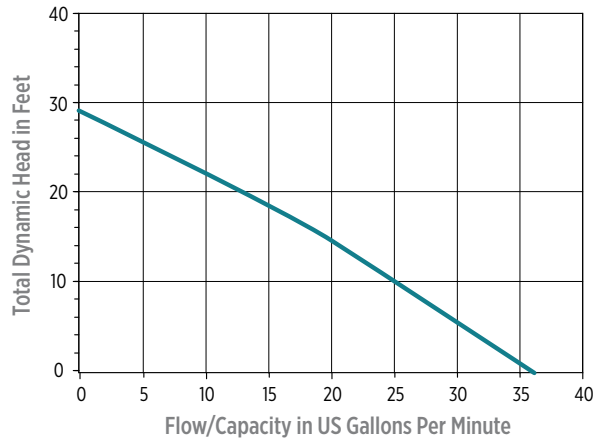

CONSTRUCTION

Motor Housing	Epoxy-coated cast aluminum
Impeller Material	Polymer
Impeller Type	Open
Volute	Aluminum
Motor Shaft	Stainless Steel
Shaft Seal	Radial Lip
Fasteners	Stainless Steel
Bearings	Ball bearing upper and lower
Power Cord	10FT
RPM	3200
Motor Type	PSC