

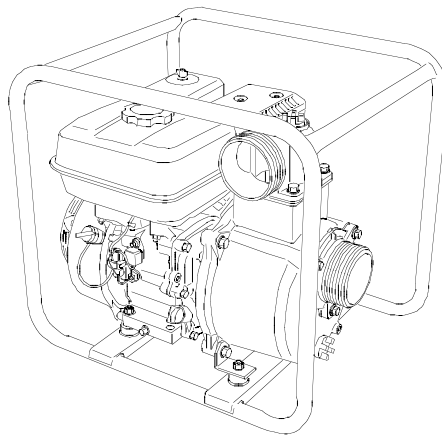

# **OPERATION, SERVICE, AND REPAIR MANUAL**

## **FOR TSURUMI TE2-SERIES CENTRIFUGAL PUMPS**



**MODELS  
TE2-50HA  
TE2-80HA  
TE2-100HA**

## LIMITED WARRANTY

TSURUMI MANUFACTURING CO., LTD. ("TSURUMI") warrants to the original end purchaser during the warranty period, every new TSURUMI pump or product to be free from defects in material and workmanship under normal use and service, when properly installed, used, and maintained (in accordance with Tsurumi's Operation, Service, and Repair Manual) for a period of two years from the date the unit was first installed or twenty six months from the date of shipment by TSURUMI to wholesaler, whichever comes first.

TSURUMI'S sole obligation under this warranty is to repair or replace at TSURUMI'S option, with new or remanufactured parts, any part(s) that fail or that are found to be defective during the warranty period. No allowance will be made for shipping charges, damages, labor, or other charges due to failure, repair or replacement.

This warranty does not apply to any TSURUMI product that has been disassembled without prior approval of TSURUMI nor does it apply to any product that has been subjected to misuse, neglect, alteration, misapplication, accident or act of God.

TSURUMI assumes no responsibility for compliance with any regulations, codes, standards, or ordinances applicable to the installation, location, operation or maintenance of its products.

No other warranty, expressed or implied, is authorized by, or applicable to, the seller. No person, agent or dealer is authorized to enlarge upon this warranty.

TSURUMI expressly disclaims liability for consequential or incidental damages or breach of expressed or implied warranty; and any implied warrant of fitness for a particular purpose and merchantability shall be limited to the duration of the expressed warranty.

Some states do not allow limitations on the duration of an implied warranty, so the above limitation or exclusion may not apply to you. Some states do not allow the exclusion or limitation of incidental or consequential damages, so the above limitation of exclusion may not apply to you.

This warranty gives you specific legal rights and you may also have other rights, which vary from state to state.

**Tsurumi Manufacturing Co., Ltd.**

# TABLE OF CONTENTS

---

<u>Section/Title</u>	<u>Page</u>
1. Introduction	1
1-1. Using Your Tsurumi Operation, Repair and Service Manual	1
1-2. Precautions	1
1-3. Safety Precautions	2
1-4. Specifications / Key Features	3
1-5. Performance Curves	3
2. Operating Instructions	6
2-1. Operating Controls	6
2-2. Check the Engine Oil Level	6
2-3. Check Engine Fuel	8
2-4. Check Fuel Level	8
2-5. Pre-Start Checks	9
2-6. Starting and Operating the Engine	9
2-7. Using the Centrifugal Pump	10
2-8. Stopping the Centrifugal Pump	10
2-9. Oil Alert	10
3. Troubleshooting	11
3-1. Troubleshooting Charts	11
4. Maintenance	12
4-1. Maintenance Schedule	12
4-2. Changing Engine Oil	13
4-3. Air Cleaner Service	14
4-4. Sediment Cup Cleaning	14
4-5. Cleaning and Adjusting Spark Plug	14
4-6. Disassembly of Centrifugal Pump	15
4-7. Replacement of Mechanical Seal	17
4-8. Removal and Installation of Engine	20
4-9. Replacement of Cushions	20
4-10. Assembly of Centrifugal Pump	22
4-11. Replacing of Check Valve	23
5. Storage Instructions	24
5-1. Procedures for Storing Pump	24
6. Replacement Parts	25
6-1. Introduction	25
6-2. Ordering Parts	25
Exploded View/Parts Listing - TE2-50HA	26/27
Exploded View/Parts Listing - TE2-80HA	28/29
Exploded View/Parts Listing - TE2-100HA	30/31

## INTRODUCTION

---

### 1-1 Using Your Tsurumi Operation, Repair and Service Manual

We thank you for purchasing a Tsurumi centrifugal pump. We are sure that the centrifugal pump you have selected will meet your portable pumping needs.

This manual applies to the Tsurumi centrifugal pumps listed below. Specifications for the centrifugal pumps are provided in the **SPECIFICATIONS** section. Key features of the centrifugal pump are shown in the **DESCRIPTION** section.

TE2-50HA  
TE2-80HA  
TE2-100HA

This manual provides instructions for operation, service, and repair of your centrifugal pump. We strongly recommend that those who operate the centrifugal pump become familiar with the centrifugal pump's features and controls, and read the operating instructions before using the centrifugal pump.

The Operation, Repair, and Service Manual provides instructions to service, checkout, and repair the centrifugal pump. This manual also provides replacement parts information.

Repair and service information for the Honda engine is provided in the Owner's Manual for Models GX160, GX240, and GX340. A copy of the Owner's Manual has been provided in the centrifugal pump's literature package. Parts information for the Honda Engine is available in Honda's Parts Catalogs.

When there are differences between centrifugal pump models, separate instructions are provided. The separate instructions are provided to make sure the correct procedures are used on the affected centrifugal pumps.

All information in the Tsurumi manuals is based upon the latest production configuration of the centrifugal pump at the time of printing.

If you have a problem with your centrifugal pump that cannot be resolved using the Operation, Repair, and Service Manual, or if you have questions about the operation, service, repair, or maintenance of your centrifugal pump, contact your local Tsurumi centrifugal pump dealer.

### 1-2 Precautions

Pay special attention to precautionary notes preceded by the words **WARNING**, **CAUTION**, and **NOTE**.

**WARNINGS** indicate that there is a strong possibility of personal injury or loss of life if the procedure is not followed, or if cleaning, lubricating, adhesives, and other materials are not used properly.

**CAUTIONS** indicate that there is a possibility of equipment damage if instructions are not followed.

**NOTES** are used in procedures to provide additional or supplemental information to make the procedure easier or more efficient.

#### **WARNING:**

- **The centrifugal pump is designed to give safe and dependable service when operated according to the instructions in the technical manual provided with the centrifugal pump.**

- **Do not operate the centrifugal pump before you have read and understand the instructions and the engine manufacturer's manual. Failure to do so could result in personal injury or equipment damage.**

## 1-3 Safety Precautions

### **WARNING:**

- **IN ORDER TO ASSURE SAFE AND EFFICIENT OPERATION OF THE CENTRIFUGAL PUMP, OPERATORS SHOULD READ AND COMPLY WITH THE FOLLOWING SAFETY PRECAUTIONS.**
- **Do not operate the centrifugal pump near gasoline or gaseous fuels because of the potential danger from explosion or fire.**
- **Do not fill the fuel tank with fuel while the engine is running.** Be careful not to spill fuel during refueling. If fuel is spilled, wipe it off and let it dry before starting the engine.
- **Do not smoke or use an open flame near the fuel tank.**
- **Do not place flammable materials near the centrifugal pump.** Be careful not to place fuel, matches, gunpowder, oily cloths, straw, or any other combustibles near the centrifugal pump.
- **Do not operate the centrifugal pump inside a room, cave, tunnel, or other insufficiently ventilated area.** Always operate the centrifugal pump in a well-ventilated area. The engine may become overheated, and the poisonous carbon monoxide gas contained in the exhaust gases will endanger human lives.
- **Keep the centrifugal pump at least 1 meter (3 feet) away from any structure or building during use.** When a centrifugal pump is located close to a building or nearby equipment, heat and exhaust from the engine will cause the surrounding temperature to rise. This will degrade the engine's cooling efficiency, causing overheating.
- **Do not enclose the centrifugal pump nor cover it with a box.** The centrifugal pump has a built-in, forced-air cooling system, and may become overheated if it is enclosed.
- **Operate the centrifugal pump on a level surface.** It is not necessary to prepare a special foundation for the centrifugal pump. However, the centrifugal pump will vibrate on an irregular surface. Therefore, choose a level place without surface irregularities.
- **Shutoff the centrifugal pump when moving the centrifugal pump to another work site.** If the centrifugal pump is tilted or moved during operation, fuel may spill and/or the centrifugal pump may tip over, causing a hazardous situation. Proper lubrication cannot be expected if the centrifugal pump is operated on a steep incline or slope. In such a case, the piston may seize; it may seize even if the oil is above the upper level.

## 1-4 Specifications / Key Features

- **Heavy-duty Honda Engine** — proven reliability — quiet operation — efficient fuel consumption
- **Oil Level Sensor** — prevents engine operation when oil level is low
- **New Design** — larger pump casing for increased durability
- **Mechanical Seal** — silicon carbide seal element for long life
- **Rubber Vibration Isolation Mounts** — isolates pump/engine vibration from the frame for maximum protection and noise reduction.
- **Durable Rolled Steel Frame** — for strength and durability
- **High Chrome Impeller** — increase ability to withstand the impact of debris passing through the pump
- **Cast Iron Volute Casing.**

MODELS		TE2-50HA	TE2-80HA	TE2-100HA	
PUMP	Pump Output	Gal./Min-to-Total Head	See Performance Curve	See Performance Curve	See Performance Curve
	Suction Size	Inches	2 NPT Male	3 NPT Male	4 NPT Male
	Discharge Size	Inches	2	3	4
ENGINE	Engine Models (Honda)	----	GX120K1-WKT2	GX160K1-WKT2	GX240K1-WKT2
	Max. HP (rpm)	hp/rpm	4.0 (3600 rpm)	5.5 (3600 rpm)	8.0 (3600 rpm)
	Displacement	CC (In <sup>3</sup> )	118	163	242
	Fuel Tank Capacity	Gals.	0.66	0.95	1.59
	Noise Level (Rated Load)	dB	64 dB	68 dB	72 dB
	Starting System	---	Recoil	Recoil	Recoil
SET	Dimensions (L x W x H)	Inches	18 1/2 x 14 5/8 x 17 1/8	28 1/2 x 16 1/2 x 18 7/8	25 x 18 x 23 1/2
	Shipping Weight	Lbs.	55	64	109

## 1-5 Performance Curves

Refer to the performance curves for the pumping capacity of TE2 series centrifugal pumps.

### GROUP PERFORMANCE

MODELS  
TE2-50HA  
TE2-80HA  
TE2-100HA

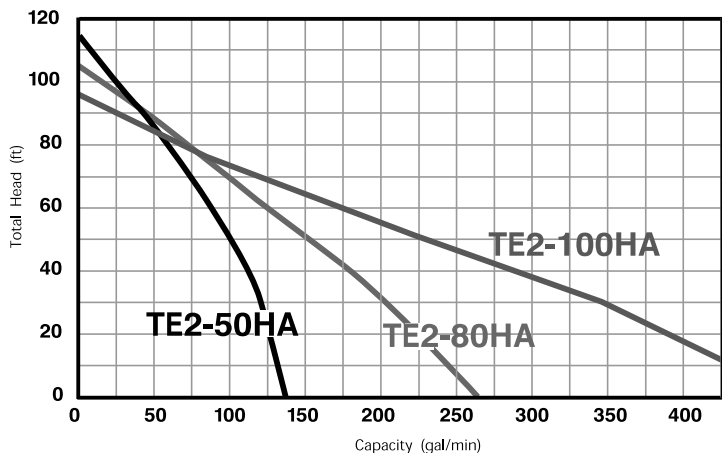

**INDIVIDUAL  
PERFORMANCE**

**MODEL  
TE2-50HA**

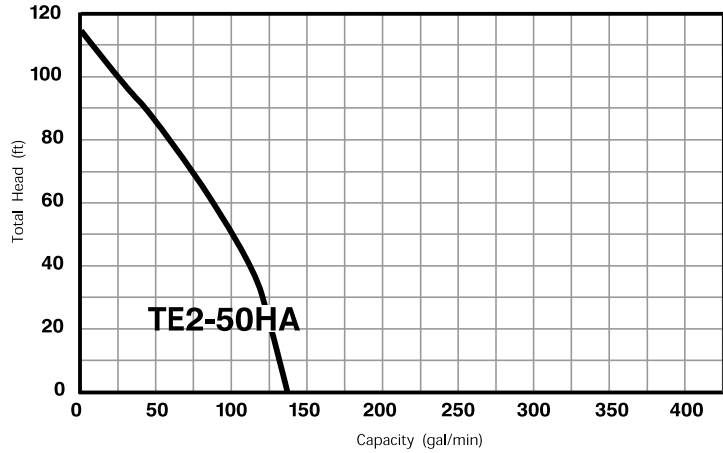

**INDIVIDUAL  
PERFORMANCE**

**MODEL  
TE2-80HA**

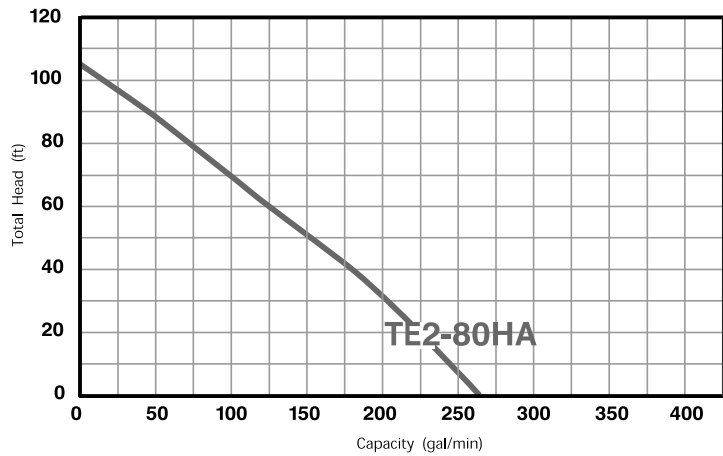

**INDIVIDUAL  
PERFORMANCE**

**MODEL  
TE2-100HA**

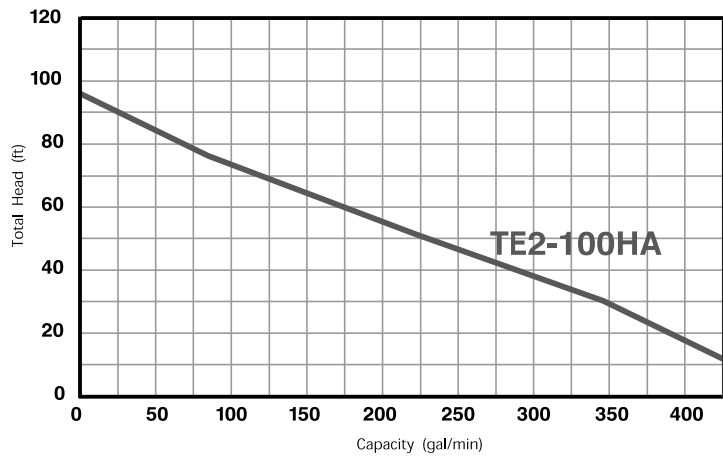

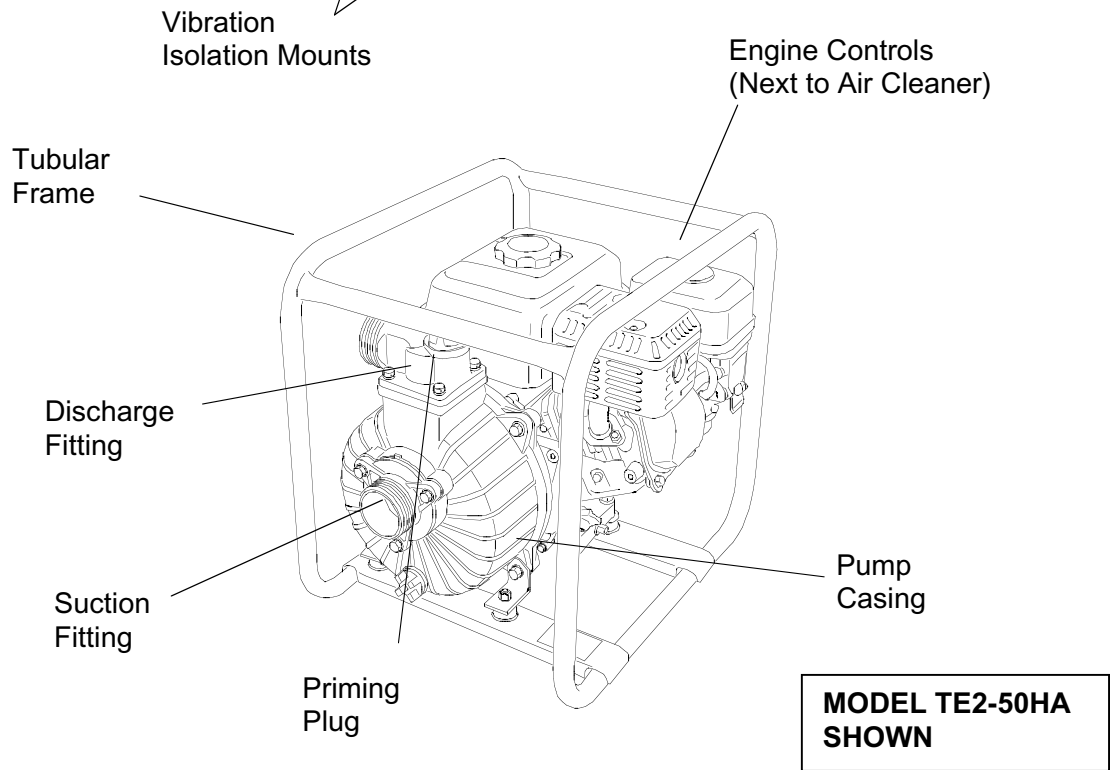
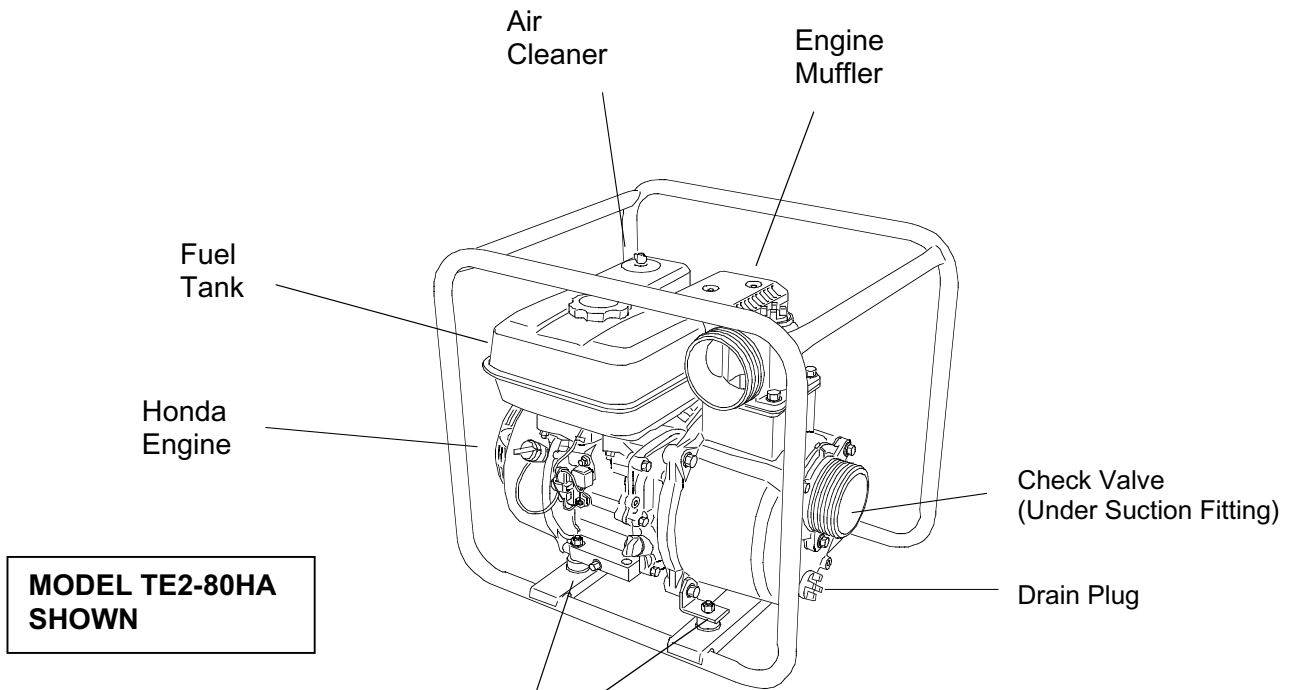



## OPERATING INSTRUCTIONS

### 2-1 Operating Controls

- A. The centrifugal pump is operated using the engine operating controls. The engine controls are located at the engine end of the pump frame.
- B. The controls consist of a throttle lever (for speed control), choke lever (for cold weather starting), fuel shutoff lever (to prevent fuel spills), and a recoil starter (to turnover engine by hand). (Refer to Figure 2-1.)

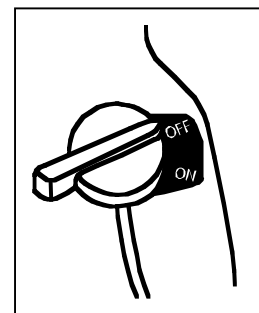
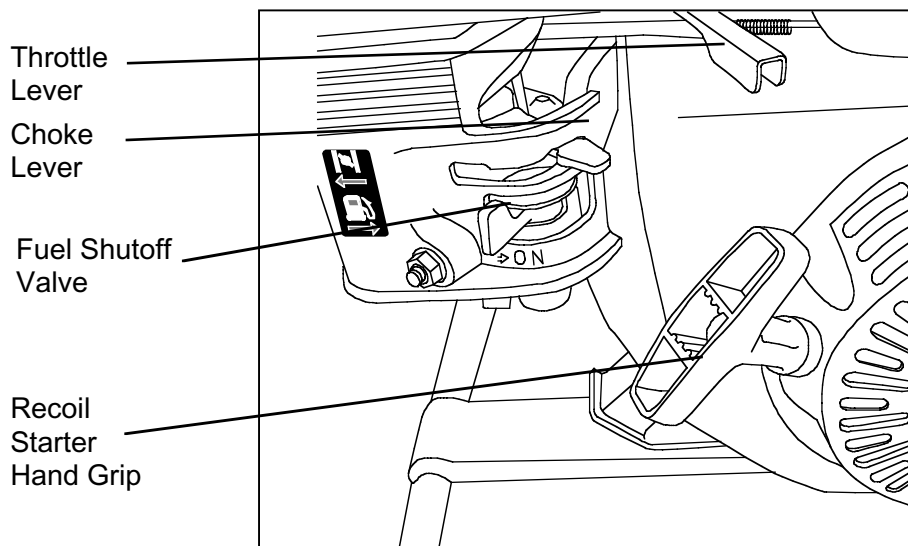

**ON/OFF Switch**

**(Located on Recoil Starter Shroud)**

**Figure 2-1: Operating Controls**

### 2-2. Check the Engine Oil Level

**CAUTION:**

- **ENGINE OIL IS A MAJOR FACTOR AFFECTING PERFORMANCE AND SERVICE LIFE. NON-DETERGENT OILS AND 2-STROKE OILS ARE NOT RECOMMENDED BECAUSE THEY HAVE INADEQUATE LUBRICATING CHARACTERISTICS**
- **CHECK THE OIL LEVEL WITH THE ENGINE ON A LEVEL SURFACE AND THE ENGINE STOPPED.**
  - A. Use Honda 4-stroke oil, or use an equivalent high detergent, premium quality motor oil certified to meet or exceed U.S. automobile manufacturer's requirements for Service Classification SG, SF. Motor oils classified SG, SF will show this designation on the container. SAE 10W/30 is recommended for general, all-temperature use.
  - B. Other viscosity grades (see Figure 2-2) may be used when the average temperature in your area is within the indicated range.

Single grade	5W						
	10W						
	20W						
	# 20						
	# 30						
	# 40						
Multi-grade	10W-30						
	10W-40						
Ambient temperature	-20	-10	0	10	20	30	40°C
	-4	14	32	50	68	86	104°F

**Figure 2-2: Oil Viscosity Grade-to-Temperature Recommendations**

- C. When checking oil, observe the following (refer to Figure 2-3):
- (1) Make sure the engine is in a level position.
  - (2) Remove the oil filler cap/dipstick and wipe it clean.
  - (3) Insert the filler cap/dipstick into the oil filler neck, but do not screw it in.
  - (4) Remove the filler cap/dipstick and check the oil level.
  - (5) If the level is low, fill to the top of the oil filler neck with the recommended oil.
  - (6) Reinstall the oil filler cap/dipstick.

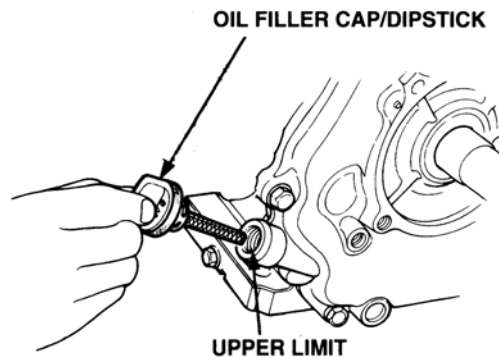

**Figure 2-3: Checking Oil Level**

## 2-3 Check Engine Fuel

### **WARNING**

- **MAKE SURE YOU REVIEW EACH WARNING IN ORDER TO PREVENT FIRE HAZARD.**
- **DO NOT REFILL TANK WHILE ENGINE IS RUNNING OR HOT.**
- **CLOSE FUEL SHUT OFF VALVE BEFORE REFUELING.**
- **BE CAREFUL NOT TO GET DUST, DIRT, WATER OR OTHER FOREIGN OBJECTS INTO FUEL.**
- **WIPE OFF SPILLED FUEL THOROUGHLY BEFORE STARTING ENGINE.**
- **KEEP AWAY FROM OPEN FLAMES.**
- **DO NOT USE SMOKING MATERIALS WHEN FILLING THE FUEL TANK.**
- **DO NOT REFUEL WHILE SMOKING OR NEAR OPEN FLAME OR OTHER SUCH POTENTIAL FIRE HAZARDS. OTHERWISE FIRE ACCIDENT MAY OCCUR.**
- **AVOID REPEATED OR PROLONGED CONTACT WITH SKIN OR BREATHING OF VAPOR.**
- **KEEP OUT OF REACH OF CHILDREN.**

## 2-4 Check Fuel Level

- A. Remove cap from fuel tank. If fuel level is low, refill with unleaded automotive gasoline.
- B. Fuel tank capacities are provided below:

TE2-50HA . . . . .	.0.95 gal.
TE2-80HA . . . . .	.1.60 gal.
TE2-100HA . . . . .	.1.70 gal.

## 2-5 Pre-Start Checks

### **WARNING:**

- **MAKE SURE YOU REVIEW EACH WARNING IN ORDER TO PREVENT FIRE HAZARD.**
- **KEEP AREA CLEAR OF FLAMMABLES OR OTHER HAZARDOUS MATERIALS.**
  - A. Check the following items before starting the engine.
    - (1) Fuel leakage from fuel hose, sediment cup, etc.
    - (2) Bolts and nuts for looseness. Components for damage or breakage.
    - (3) Check centrifugal pump surroundings.
      - (a) Keep centrifugal pump at least three (3) feet (one [1] meter) away from buildings or other structures.
      - (b) Only operate centrifugal pump in a dry, well-ventilated area.
      - (c) Keep exhaust pipe clear of foreign objects.
      - (d) Keep centrifugal pump away from open flame.

## 2-6 Starting and Operating the Engine

- A. Refer to the Honda engine owner's manual.
- B. Put the fuel valve in the ON position.
- C. Move the choke lever to the closed position.

**NOTE:**

- The choke may not be needed if the engine is warm or the air temperature is high.
  - D. Set the ON/OFF switch to ON (the ON/OFF switch is mounted on the recoil shroud).
  - E. Move the throttle lever slightly to the left.
  - F. Pull the starter grip lightly until resistance is felt, then pull briskly.

**NOTE:**

- Do not allow the starter grip to snap back against the engine. Return it gently to prevent damage to the starter.
  - G. As the engine warms up, gradually move the choke lever to the OPEN position.

## **2-7 Using the Centrifugal Pump**

- A. Connect suction and discharge hoses. Make sure suction hose is fitted with a strainer.
- B. Remove priming plug from top of pump and fill chamber with water.
- C. Operate the engine at idle speed for 3 to 5 minutes.
- D. After engine warm up, move the throttle lever to the operating speed.

## **2-8 Stopping the Centrifugal Pump**

- A. Move the throttle lever fully to the right.
- B. Set the ON/OFF switch to OFF.
- C. Turn the fuel valve to the OFF position.

## **2-9 Oil Alert**

- A. The oil alert sensor detects the lowering of the oil level in the crankcase and automatically stops the engine when the oil level falls below the predetermined level.
  - (1) When the engine stops automatically, check the oil level. Refill engine oil to the upper level and restart the engine.
  - (2) If the engine does not start by usual starting procedures, check the oil level.

## TROUBLESHOOTING

The troubleshooting tables below can be used as a guide to isolate centrifugal pump faults. Refer to these tables when the engine fails to start after several attempts. If, after following these procedures, the pump fails to start, contact the nearest Tsurumi pump dealer.

**Table 3-1: Troubleshooting Table**

Fault	Probable Cause	Remedy
Pump does not pump.	Insufficient priming water. Mechanical seal chipped or broken. Check valve damaged. Suction hose damaged or strainer clogged. Air leaks caused by O-ring damage.	Add more water through priming plug. Replace mechanical seal. Replace check valve. Replace hose. Clean strainer. Replace O-rings.
Discharge flow or pump pressure too low.	Air leaks caused by O-ring damage. Suction hose or strainer clogged.  Excessive impeller clearance.  Engine rpm too low.  Lift head too high.	Replace O-rings. Replace hose. Clean strainer. Disassemble to obtain casing cover and impeller. Determine clearance and re-shim as required (refer to Replacement of Mechanical Seal). Check rpm and reset throttle as required. Lower lift head.
Pump primes too slowly.	Insufficient priming water. Mechanical seal chipped or broken. Check valve damaged. Suction hose damaged or strainer clogged.  Air leaks caused by O-ring damage. Engine rpm too low.  Lift head too high.	Add more water through priming plug. Replace mechanical seal. Replace check valve. Replace hose. Clean strainer. Replace O-rings.  Check rpm and reset throttle as required. Lower lift head.
Noise or vibration.	Faulty mounting.	Pump/engine attaching parts loose. Tighten as required. Damaged vibration isolation mounts. Replace mounts.

## MAINTENANCE

---

### 4-1 Maintenance Schedule

To maintain the centrifugal pump in peak operating condition, observe and implement the maintenance and adjustment schedule in Table 4-1. Inspect and/or service the centrifugal pump at the intervals shown in Table 4-1.

**WARNING:**

- **SHUT OFF THE ENGINE BEFORE PERFORMING ANY MAINTENANCE. IF OPERATION OF THE ENGINE IS REQUIRED, MAKE SURE THE AREA IS WELL VENTILATED; THE ENGINE EXHAUST CONTAINS POISONOUS CARBON MONOXIDE GAS.**

**CAUTION:**

- **REFER TO THE HONDA ENGINE OWNER'S MANUAL FOR OTHER MAINTENANCE REQUIREMENTS.**

**Table 4-1: Maintenance Schedule**

Frequency	Maintenance Action
Daily	Check oil level.  Check all components according to the PRE-OPERATIONAL CHECKS section.
50 Hours	Wash cleaner element.  Check spark plug and clean if necessary.
100 Hours	Change engine oil.
200 Hours	Adjust spark plug gap.  Clean fuel strainer.
500 Hours (12 Months)	Replace spark plug and cleaner element.  Clean and adjust carburetor, valve clearance, and valve seat along with cylinder head.
1,000 Hours (24 Months)	Check rotor and stator.  Replace engine isolation mounts.  Overhaul engine.  Change fuel lines.

## 4-2 Changing Engine Oil

- A. An initial oil change should be performed after the first twenty- (20) hours of use. Thereafter, change oil every 100 hours.
- B. Before changing the oil, check for a suitable way to dispose of the used oil. Do not pour it down sewer drains, onto garden soil or into open streams. Refer to your local zoning and environmental regulations for disposal and handling requirements.
- C. Drain the oil while the engine is still warm to assure rapid and complete draining.
- D. Remove the oil filler dipstick/cap and drain plug. Allow oil to drain from the engine (refer to Figure 4-1).

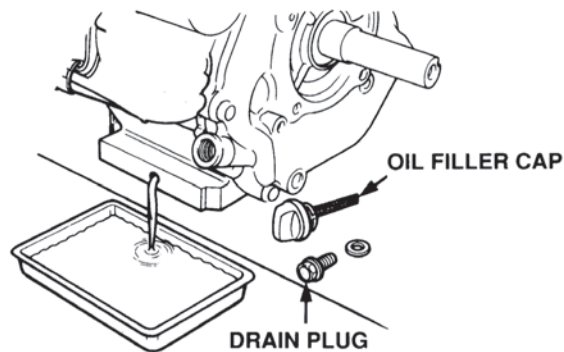

Figure 4-1: Draining Engine Oil

- E. Install the drain plug, and tighten it securely.
- F. Refill with the recommended oil (refer to Figure 2-2).
- G. After filling with oil, check the oil level.
- H. When oil reaches the upper limit, install the oil filler dipstick/cap (Figure 4-2).

### **NOTE:**

- Engine oil capacity: 1.1 liters (1.16 U.S. Quart)

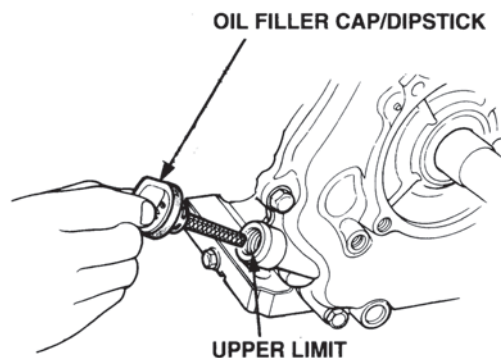

Figure 4-2: Checking Oil Level



### 4-3 Air Cleaner Service

**WARNING:**

- **NEVER USE GASOLINE OR LOW FLASH POINT SOLVENTS FOR CLEANING THE AIR CLEANER ELEMENT. A FIRE OR EXPLOSION COULD RESULT.**

**CAUTION:**

- **NEVER RUN THE ENGINE WITHOUT THE AIR CLEANER. RAPID ENGINE WEAR WILL RESULT FROM CONTAMINANTS, SUCH AS DUST AND DIRT, BEING DRAWN THROUGH THE CARBURETOR AND INTO THE ENGINE.**
  - A. A dirty air cleaner will restrict airflow to the carburetor.
  - B. To prevent degraded engine operation, service the air cleaner regularly. Service more frequently when operating the engine in extremely dusty areas.

### 4-4 Sediment Cup Cleaning

**WARNING:**

- **GASOLINE IS EXTREMELY FLAMMABLE AND IS EXPLOSIVE UNDER CERTAIN CONDITIONS. DO NOT SMOKE OR ALLOW OPEN FLAMES OR SPARKS IN THE AREA.**
  - A. Turn the fuel valve to OFF (refer to Figure 2-1).
  - B. Remove the sediment cup and O-ring. Wash both parts in nonflammable or high flash point solvent.
  - C. Wipe the sediment cup and O-ring dry, then reinstall.

**WARNING:**

- **AFTER INSTALLING THE SEDIMENT CUP, CHECK FOR LEAKS, AND MAKE SURE THE AREA IS FREE OF RESIDUAL FUEL SPILLS OR SEEPAGE BEFORE STARTING THE ENGINE.**
  - D. Set the fuel shutoff valve (Figure 2-1) to ON.
  - E. Check for leaks.

### 4-5 Cleaning and Adjusting Spark Plug

Recommended spark plugs: BPR6ES(NGK)  
W20EPR-U (NIPPONDENSO)

- A. To ensure proper engine operation, the spark plug must be properly gapped and free of deposits.
- B. Remove the spark plug cap.
- C. Clean any dirt from around the spark plug base.
- D. Use the proper size spark plug wrench to remove the spark plug.

**WARNING:**

- **THE MUFFLER BECOMES VERY HOT DURING OPERATION AND REMAINS HOT FOR A WHILE AFTER STOPPING THE ENGINE. BE CAREFUL NOT TO TOUCH THE MUFFLER WHILE IT IS HOT.**
- E. Visually inspect the spark plug. Discard spark plug if the insulator is cracked or chipped. Clean the spark plug with a wire brush if it is to be reused.
- F. Measure the plug gap with a feeler gauge. Adjust the gap as necessary by bending the side electrode (refer to Figure 4-3).
- G. The gap should be 0.7 - 0.8 mm (0.028 - 0.031 inch) as shown.

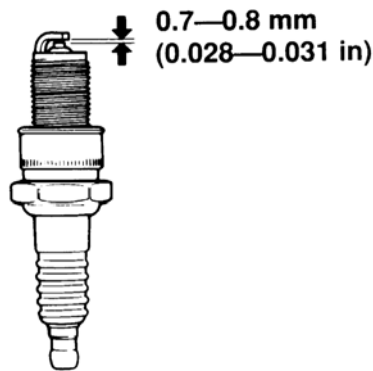

**Figure 4-3: Spark Plug Gap**

## 4-6 Disassembly of Centrifugal Pump

**WARNING:**

- **THE SHIPPING WEIGHT OF THE MODEL TE2-SERIES PUMPS RANGE FROM 55 TO 109 POUNDS. TO AVOID PERSONAL INJURY, USE AN OVERHEAD LIFTING DEVICE OR GAIN THE ASSISTANCE OF ANOTHER PERSON TO LIFT THE PUMP ON AND OFF THE BENCH.**
- **IT IS RECOMMENDED THAT THE PUMP BE ASSEMBLED AND DISASSEMBLED ON A BENCH OR SIMILAR SURFACE WITH THE ENGINE SHROUD FACING DOWN. IN ADDITION, WOODEN BLOCKS IN A VARIETY OF LENGTHS AND THICKNESSES SHOULD BE AVAILABLE FOR SUPPORT OF THE ENGINE AFTER PUMP REMOVAL.**

**NOTE:**

- Exception notes are provided where the procedures differ between pump models.
- Separate parts listings are provided for each model of centrifugal pump.
- The item numbers in procedures correspond with the item numbers used in the **REPLACEMENT PARTS** section of the manual. Refer to exploded view in Figure 4-4 for parts location.
- Use wooden blocks to steady and support frame (21) and engine (33) during disassembly and assembly.

**A. Remove Centrifugal Pump Components**

- (1) Remove two screws (30) from bracket (25) and pump casing (1). Remove two spring nuts (27) and two brackets (25).
- (2) Position the frame (21) so the pump is facing up (with the engine shroud down).
- (3) Remove four bolts (18) and lift casing (1) from casing cover (2).
- (4) Remove volute casing (4), packing (9), and O-ring (8). Check packing (9) and O-ring (8) for damage and replace if damaged.

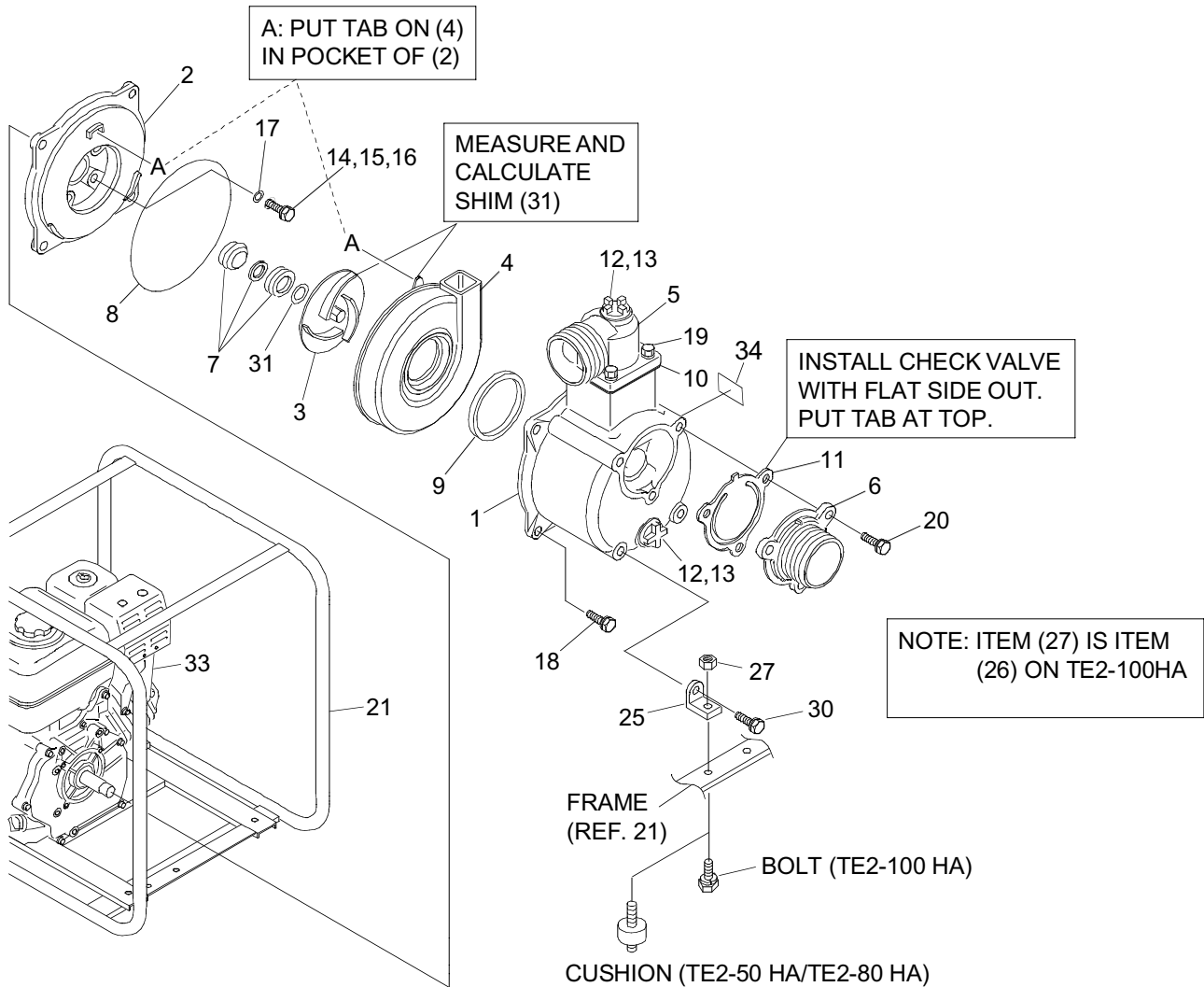

**Figure 4-4: Removal of Internal Components**

- (5) Using a hard plastic hammer, sharply rap on the end of the hex on impeller (3). If impeller (3) did not come loose, put a wooden block against one of the impeller vanes. Then strike the wooden block (counterclockwise) with a hammer to loosen the impeller.
- (6) Rotate impeller (3) until it can be removed from the threaded end of the engine crankshaft.

- (7) If installed, remove shim (31) from bore in impeller (or remove shim from end of engine crankshaft).
- (8) Remove four bolts (14), spring washers (15), plain washers (16), and seals (17). Remove casing cover (2) from the engine (33). Check the condition of seals (17) and replace if damaged.
- (9) Assemble the centrifugal pump according to the procedures in **Assembly of the Centrifugal Pump** unless one of the following applies:
  - (a) If the pump has been disassembled to replace mechanical seal (7), refer to **4-8. Replacement of Mechanical Seal** for replacement procedures.
  - (b) If the pump has been disassembled to replace cushions (23 or 24), refer to **4-9. Replacement of Cushions** for replacement procedures.
  - (c) If the pump has been disassembled to remove or replace engine (33), refer to **4-10. Replacement of Engine** for replacement procedures.

## 4-7 Replacement of Mechanical Seal

### A. Description of the Mechanical Seal

- (1) The mechanical seal (7) is a two part seal. The seal consists of a fixed element and a rotating element.
- (2) The fixed element is installed in the center bore of the cover casing. The fixed element is sealed between the seal and the center bore that is provided by a strip of sealant on the outside diameter of the seal.
- (3) The rotating element is installed in the center bore of the impeller. The rotating element consists of a silicone-carbide mating ring and a close-fitting rubber cushion.
- (4) A static seal is provided between the pump casing and the volute casing.

### B. Removal of Mechanical Seal

- (1) Disassemble the pump only to the extent required to access the seal in casing cover (2) and impeller (3). Refer to Remove Centrifugal Pump Components.
- (2) Remove old mechanical seal (7) from casing cover (2) using a driver similar to the driver in Figure 4-5.

### **NOTE:**

- Sealant is used on the outside diameter of mechanical seal (7). The sealant has a strong bond in the casing cover bore and requires considerable driving force to remove the seal. Use of an arbor press is therefore recommended.

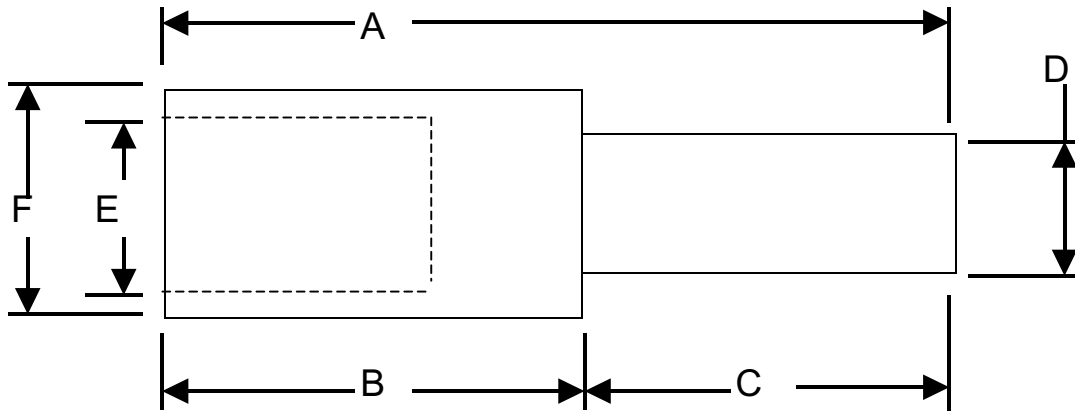

**LEGEND**

- A = B + C (Tool length)
- B = Overall uninstalled height of mechanical seal.
- C = Length of casing cover center bore from start of bore to face of installed seal. Multiply length times 2.
- D = Outside diameter of tool to have a slip fit with inside diameter of mechanical seal.
- E = Inside diameter of recess to be sized to fit over the mechanical seal. Recess depth to be enough to contact only the cup flange of the mechanical seal.
- F = Outside diameter to be same diameter as the cup flange on mechanical seal.  
(The outside diameter of the tool should be sized to have a slip fit with the center bore of the casing cover (2). The inside diameter of the tool should be sized so the tool contacts the metal cup of the seal.)

**Figure 4-5: Mechanical Seal Installation/Removal Tool**

- (3) Clean bore in casing cover to remove all traces of sealant residue.
- (4) Take the measurements needed for calculating the thickness of shim (31). The shim is sized to provide clearance between the casing cover (2) and impeller (3).
  - (a) Refer to Figures 4-6. Measure and record dimension A.
  - (b) Refer to Figures 4-7. Measure and record dimension B.
  - (c) Subtract dimension B from dimension A. The resultant dimension is the thickness of the shim (31).

$$\begin{array}{rcccl}
 \mathbf{A} & \underline{\hspace{2cm}} & \mathbf{Minus} & \mathbf{B} & \underline{\hspace{2cm}} & = & \underline{\hspace{2cm}} \\
 \text{(Depth of Volute Casing)} & & & \text{(Height of Installed Impeller)} & & & \text{(Shim Thickness)}
 \end{array}$$

- (5) Select the combination of shims (31) (see Figure 4-8) that will provide clearance of 0.020 inch to 0.040 inch (0.508 mm to 1.016 mm). Temporarily set shims (31) aside for installation later.
- (6) Complete assembly of the centrifugal pump according to the procedures in **Assembly of the Centrifugal Pump**.

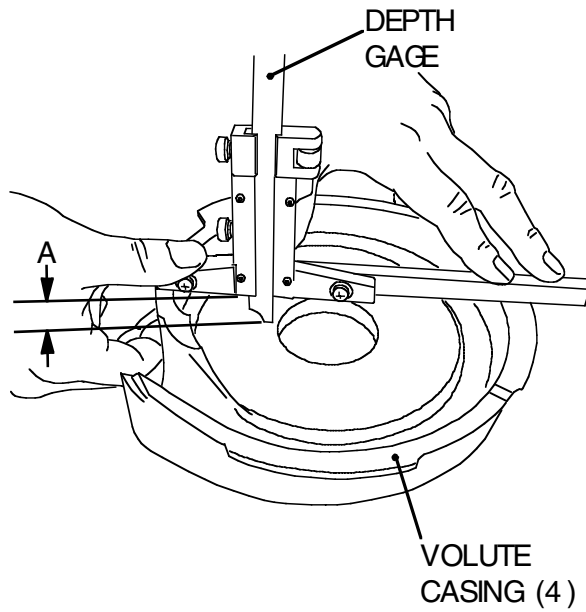

**Figure 4-6: Measuring Volute Casing**

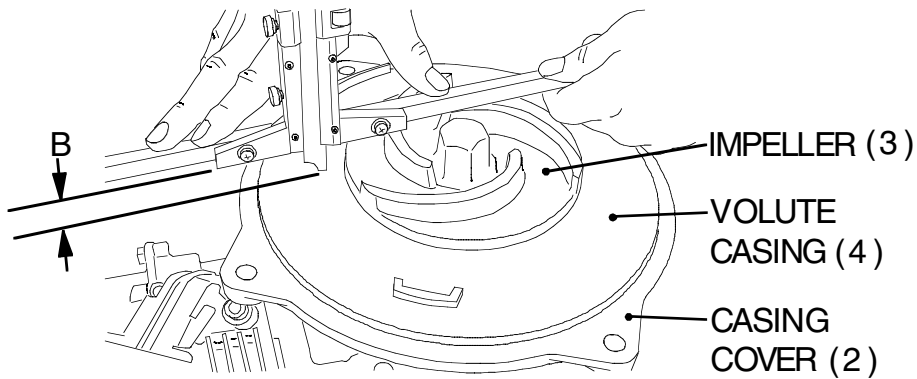

**Figure 4-7: Measuring Impeller Depth**

Model Number	Shim Thickness	OD x ID	Part Number
TE2-50HA	0.3 mm (0.012 Inch)	20 x 18 mm (0.787 x 0.709 inch)	801-037
	0.6 mm (0.024 Inch)		801-038
TE2-80HA	0.3 mm (0.012 Inch)	24.2 x 20.0 mm (0.952 x 0.787 inch)	1001-043
	0.6 mm (0.024 Inch)		1001-044
	1.0 mm (0.039 Inch)		1001-045
TE2-100HA	0.3 mm (0.012 Inch)	* 22.2 mm (0.874 inch)	1001-040
	0.6 mm (0.024 Inch)		1001-041
	1.6 mm (0.063 Inch)		1001-042
	0.3 mm (0.091 Inch)		1001-043

\* Noted shim is a disk and does not have an inside diameter. OD = Outside Diameter / ID = Inside Diameter

**Figure 4-8: Shim Dimensions**

## 4-8 Removal and Installation of Engine

- A. If you need to remove or replace engine (33) to access cushions (23 or 24), proceed as follows:
- (1) Refer to exploded view in **REPLACEMENT PARTS** section for parts location. Remove nuts (26 and 27). Lift engine (33) off threads of cushions (23 and 24) in frame (21).
  - (2) Check condition of cushions (23 and 24). Replace any damaged cushions.
  - (3) Position frame (21) so the engine (33) is in normal operating position (with fuel tank up).
  - (4) Remove two nuts (26) from cushions (24) in mounting flange of engine (33).
  - (5) Lift engine from threaded ends of cushions (24).
  - (6) Align holes in mounting flange of replacement engine over the threaded ends of the cushions (24).
- B. Assemble remaining components according to the instructions in **4-11. Assembly of Centrifugal Pump**.

## 4-9 Replacement of Cushions

### NOTE:

- Use wooden blocks to support the centrifugal pump frame during disassembly and assembly.
- Refer to Figure 4-4 for location of parts used on Models TE2-50HA and TE2-80A.

### **A. Replacement of Pump Cushions (24) on Models TE2-50HA and TE2-80A.**

- (1) Remove screws (30) from casing (2) and brackets (25).
- (2) Remove nuts (27) and brackets (25) from threaded end of cushions (24).
- (3) Remove nuts (26) from threaded end of cushion (24) (on the underside of frame crossover support). Remove cushions and check for damage; replace damaged cushions.
- (4) Install threaded end of new cushions (24) through holes at pump end of frame. Secure with nuts.
- (5) Install short end of new cushions (23) through holes at engine end of frame. Secure with nuts (26).

### NOTE:

- Refer to Figure 4-9 for location of parts used on Models TE2-100HA.

### **B. Replacement of Engine Cushions (23) on Model TE2-100HA.**

- (1) Remove pump components according to the instructions in **4-11. Remove Centrifugal Pump**.

- (2) Remove nuts (26) and bolts (28) from base (22). Remove engine (33) from base (22).
- (3) Remove nuts (26) from threaded ends of cushions (23).
- (4) Lift the base (22) from cushions (23).
- (5) Remove nuts (26) from underside of frame (22) and check cushions for damage. Replace damaged cushions.
- (6) Install threaded end of new cushions (23) through holes at pump end of frame (21). Secure with nuts (26).
- (7) Install short end of new cushions (23) through holes at engine end of frame. Secure with nuts (26).

**CAUTION:**

- **MAKE SURE YOU CHECK TIGHTNESS OF THE FOUR NUTS (26) ON THE UNDERSIDE OF THE FRAME. TIGHTENING THE NUTS ON THE TOP SIDE OF THE FRAME MAY LOOSEN THE NUTS ON THE UNDERSIDE OF THE FRAME.**
- (8) Install base (22) over the long threaded ends of cushions (23). Tighten nuts (23).
  - (9) Install engine (33) on base (22). Align boltholes in flange of engine (33) with holes in base (22).

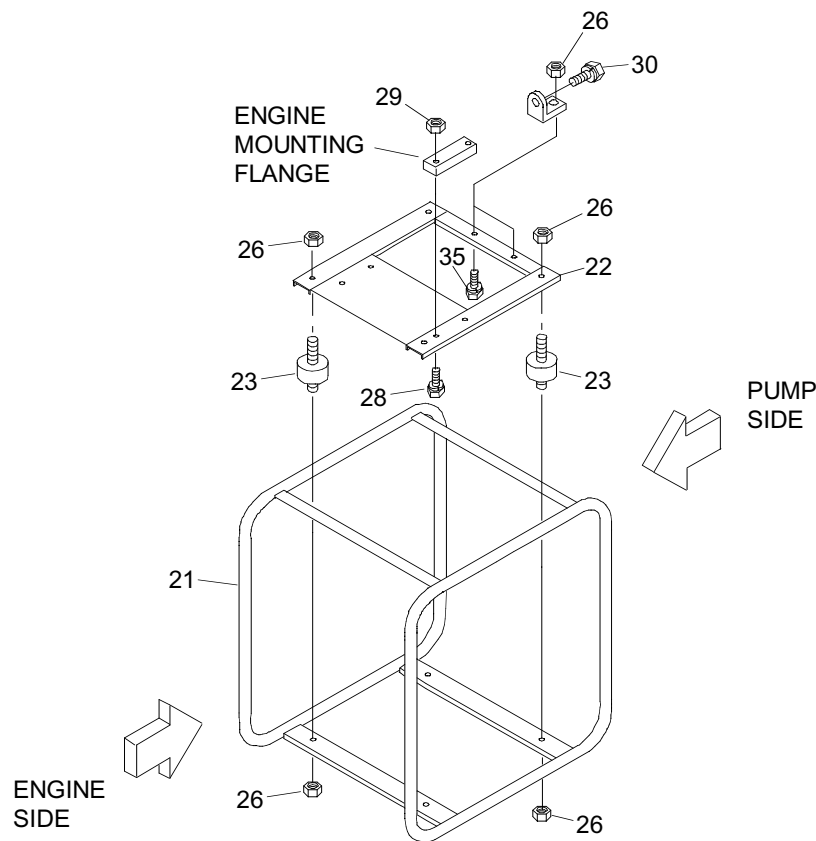

**Figure 4-9: Exploded View for Frame and Base of Model TE2-100HA Pump**



- (10) Install bolts (28) from underside of base (22) through holes in engine mounting flange and secure with nuts (29).
- (11) Install remaining components. Refer to **Assembly of Centrifugal Pump** for installation procedures.

## 4-10 Assembly of Centrifugal Pump

### **WARNING:**

- **THE SHIPPING WEIGHT OF THE MODEL TE2-SERIES PUMPS RANGE FROM 55 TO 109 POUNDS. TO AVOID PERSONAL INJURY, USE AN OVERHEAD LIFTING DEVICE OR GAIN THE ASSISTANCE OF ANOTHER PERSON TO LIFT THE PUMP ON AND OFF THE BENCH.**
- **IT IS RECOMMENDED THAT THE PUMP BE ASSEMBLED AND DISASSEMBLED ON A BENCH OR SIMILAR STRUCTURE WITH THE ENGINE SHROUD FACING DOWN. IN ADDITION, WOODEN BLOCKS IN A VARIETY OF LENGTHS AND THICKNESS SHOULD BE AVAILABLE FOR SUPPORT OF THE ENGINE AFTER PUMP REMOVAL.**

### **NOTE:**

- Separate parts listings are provided for each model of centrifugal pump. Make sure you order parts from the listing for your model of centrifugal pump (the model number is provided on the pump nameplate).
- Use wooden blocks to steady and support the frame (21), the pump, and the engine (33) during disassembly and assembly.
- These procedures assume that the engine is installed.
- Installation instructions for mechanical seal (7) are contained in **4-7. Replacement of Mechanical Seal.**
  - A. Position frame (21) with the engine (33) in normal operating position (with fuel tank up).
  - B. Make sure the fixed element of mechanical seal (7) is installed in casing cover (2).
  - C. Make sure the rotating element of mechanical seal (7) is installed in impeller (3). (The rotating element of the mechanical seal consists of the rubber cushion and mating ring.)
  - D. Position casing cover (2) against the engine with the center bore cutout in casing cover (2) facing downward at the bottom of the frame.
  - E. Install bolts (14), spring washers (15), plain washers (16), and seals (17) in holes in casing cover (2). Replace seals (17) if damaged.
  - F. Install O-ring (8) on casing cover (2).
  - G. If a new mechanical seal has been installed, take measurements and select shims required to provide clearance between the impeller (3) and the casing cover (2). Refer to **Replacement of Mechanical Seal** for shim measurement procedures.
  - H. Install shim (31) in bore of impeller (3).

- I. Install impeller on end of engine crankshaft (32) and rotate impeller (3) (clockwise) until tight.
- J. Install packing (9) over raised lip on volute casing (4).
- K. Install volute casing (4). Align tab on volute casing (4) with raised alignment marks at the 0-degree position on casing cover (2). (The volute casing should also be constrained by raised alignment marks at the 135-degree and 225-degree positions on the casing cover.)
- L. Install casing (1) over volute casing (4) and onto casing cover (2). Install four bolts (18).
- M. Install two brackets (25) over threaded end of cushion (24). Install two screws (30) through bracket and into casing (1); do not tighten.
- N. Install nuts (26) on threaded end of cushions (24).
- O. Tighten screws (30) and nuts (26).

#### **4-11 Replacement of Check Valve**

- A. Remove three bolts (20), check valve (11), and suction case (6).
- B. Discard damaged check valve (11).
- C. Place the flat side of the replacement check valve (11) against the flat side of the suction case (6). Position the check valve (11) with the valve pivot point in the top (zero degree position).
- D. Align boltholes in replacement check valve (11) and suction case (6). (Refer to Figure 4-4 for the correct orientation).
- E. Attach suction case (6) to pump casing (1) using bolts (20)

## STORAGE

---

### 5-1 Procedures for Storing Pump

**WARNING:**

- **To avoid severe burns or fire hazards, let the engine cool before transporting it or storing it indoors.**
- **When transporting the pump, turn the fuel shutoff valve to the OFF position and keep the engine level to prevent fuel spillage. Fuel vapor or spilled fuel may ignite.**
  - A. The following procedures should be followed before storing your pump for periods of 6 months or longer.
    - (1) Carefully drain fuel from the fuel tank; gasoline left in the fuel tank will eventually deteriorate making engine starting difficult.
    - (2) Remove the carburetor float chamber and also drain the carburetor.
    - (3) Change engine oil.
    - (4) Check for loose bolts and screws; tighten if necessary.
    - (5) Clean pump thoroughly with oiled cloth. Spray with preservative if available. **NEVER USE WATER TO CLEAN PUMP!**
    - (6) Pull starter handle until resistance is felt, leaving handle in that position.
    - (7) Store pump in a well-ventilated, low humidity area.

## REPLACEMENT PARTS

---

### 6-1 Introduction

This section provides exploded view illustrations that show the replacement parts for Tsurumi Centrifugal Pumps, Models TE2-50HA, TE2-80HA, and TE2-100HA. Also provided are parts listings that provide part number, description, and quantity. The item numbers shown on the illustrations correspond with the item numbers in the facing parts listing.

### 6-2 Ordering Parts

Order replacement parts from:

Tsurumi (America), Inc.  
845 North Dillon Drive  
Wood Dale, IL 60191  
Tel: 1-888-878-7864  
Fax: 1-630-766-6445  
E-mail: [info@tsurumi-america.com](mailto:info@tsurumi-america.com)

# Exploded View - Model TE2-50HA Centrifugal Pump

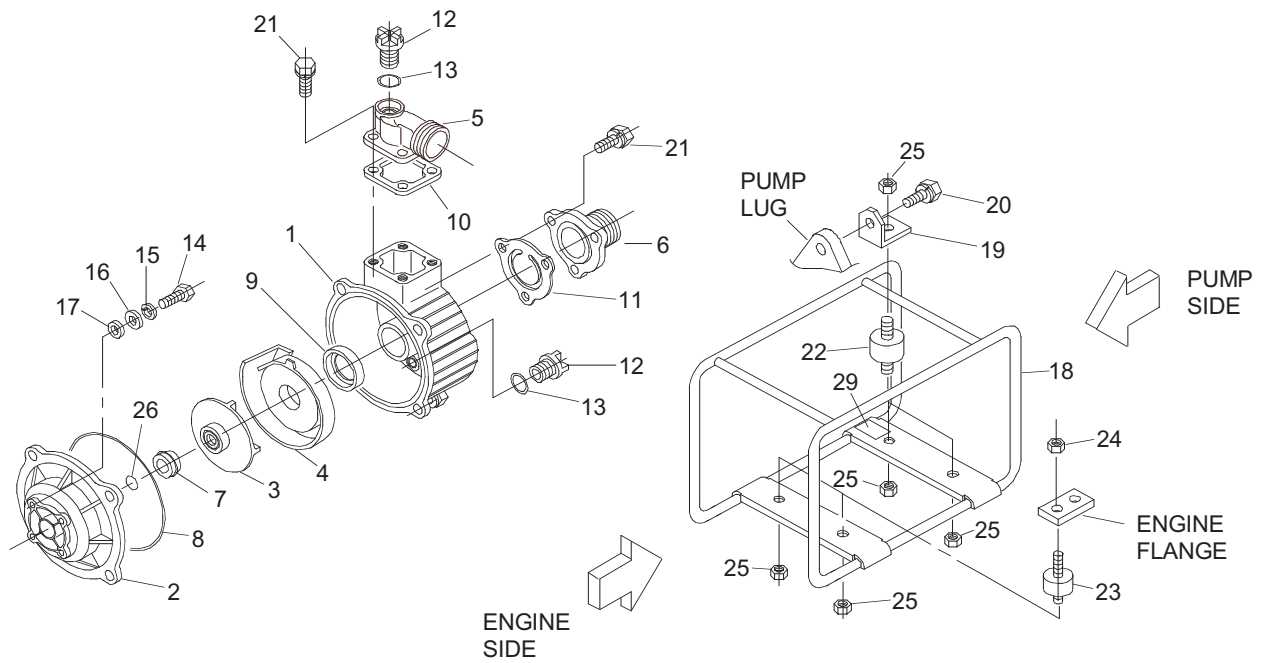

## Parts List - Model TE2-50HA Centrifugal Pump

Ref. No.	Part Number	Description	Size	Qty
1	507-001	Casing		1
2	501-004	Cover, Casing		1
3	501-009	Impeller		1
4	501-011	Casing, Volute		1
5	501-019A	Bend, Discharge	2- Inch NPT	1
6	501-013A	Flange, Suction	2- Inch NPT	1
7	521-008	Seal, Mechanical		1
8	501-002	O-Ring	209.55 x 3.05	1
9	501-012	Packing	52 x 70 x10t	1
10	501-020	Packing	50 x 84 x 2t	1
11	501-015	Valve, Check		1
12	501-021	Plug *		2
13	501-022	O-Ring *		2
14	501-005	Bolt, Hex	M8 x 48L	4
15	821-007	Washer, Spring	M8	4
16	501-008	Washer, Plain	M8	4
17	501-006	Seal, Packing	7.8 x 13.5 x 3.3t	4
18	501-030HV	Frame, Cage		1
19	501-038	Bracket		2
20	501-003	Bolt, Hex	M10 x 30 (SW) (Bracket to Pump)	2
21	501-014	Bolt, Hex	M8 x 25L (SW) (Discharge Bend) (Suction Flange)	7
22	1001-032	Cushion, Rubber	Pump Side	2
23	501-037	Cushion, Rubber	Engine Side	2
24	501-024	Nut, Spring	M8 (F) (Engine to Cushion)	2
25	1001-024	Nut, Spring	M8 (F) (Cushions to Frame) (Pump to Cushion)	6
26	501-042	Shim, Impeller	18 x 14 x 0.3t	AR
-27	13310-ZEO-631	Crankshaft **		1
-28	GX120 K1WKT2	Engine, Honda ***		1
29	TBD	Nameplate		1

AR = As Required; quantity determined at assembly.

\* Plug (12) includes O-ring (13).

\*\* Crankshaft (-28) has special metric thread. Order Tsurumi replacement crankshaft (-28) (not Honda).

\*\*\* Contact Honda distributor for Honda engine parts.

(-) Items prefixed with a dash are not illustrated.

# Exploded View - Model TE2-80HA Centrifugal Pump

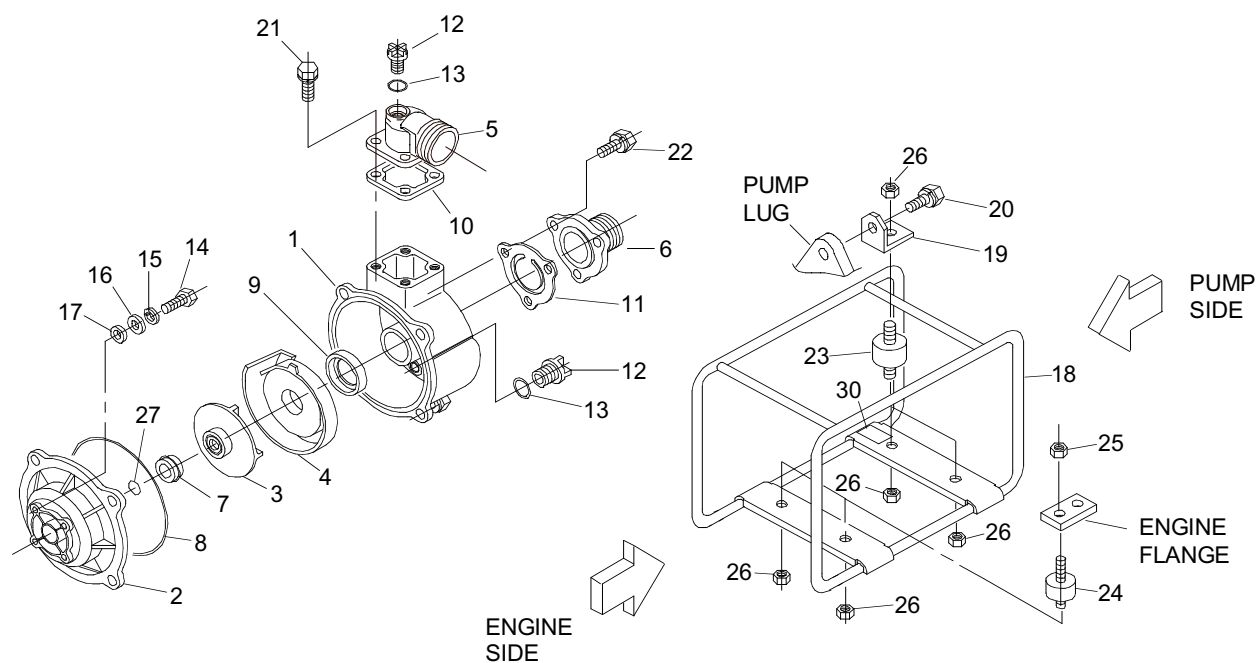

## Parts List - Model TE2-80HA Centrifugal Pump

Ref. No.	Part Number	Description	Size	Qty
1	803-001	Casing		1
2	501-004	Cover, Casing		1
3	801-009	Impeller		1
4	801-011	Casing, Volute		1
5	801-019A	Bend, Discharge	3- Inch NPT	1
6	801-013A	Flange, Suction	3- Inch NPT	1
7	521-008	Seal, Mechanical		1
8	501-002	O-Ring	209.55 x 3.05	1
9	801-012	Packing	67 x 86 x10t	1
10	801-020	Packing	75 x 105 x 2t	1
11	801-015	Valve, Check		1
12	501-021	Plug *		2
13	501-022	O-Ring *	P-24 (3.5)	2
14	501-005	Bolt, Hex	M8 x 48L	4
15	501-007	Washer, Spring	M8	4
16	501-008	Washer, Plain	M8	4
17	501-006	Seal, Packing	7.8 x 13.5 x 3.3t	4
18	801-030HV	Frame, Cage		1
19	501-038	Bracket		2
20	501-003	Bolt, Hex	M10 x 30L (SW) (Bracket to Pump)	2
21	501-014	Bolt, Hex	M8 x 25L (SW) (Discharge Bend)	4
22	801-014	Bolt, Hex	M8 x 30L (SW) (Suction Flange)	3
23	1001-032	Cushion, Rubber	Pump Side	2
24	501-037	Cushion, Rubber	Engine Side	2
25	501-024	Nut, Spring	M8 (F) (Engine to Cushion)	2
26	1001-024	Nut, Spring	M8 (F) (Cushion to Frame) (Bracket to Cushion)	6
27	801-037	Shim, Impeller	20 x 18 x 0.3t	AR
-28	13310-ZE1-630	Crankshaft **		1
-29	GX-160 K1WKT2	Engine, Honda ***		1
30	801-027	Nameplate		1

AR = As Required; quantity determined at assembly.

\* Plug (12) includes O-ring (13).

\*\* Crankshaft (-28) has special metric thread. Order Tsurumi replacement crankshaft (-28) (not Honda).

\*\*\* Contact Honda distributor for Honda engine parts.

(-) Items prefixed with a dash are not illustrated.



# Exploded View - Model TE2-100HA Centrifugal Pump

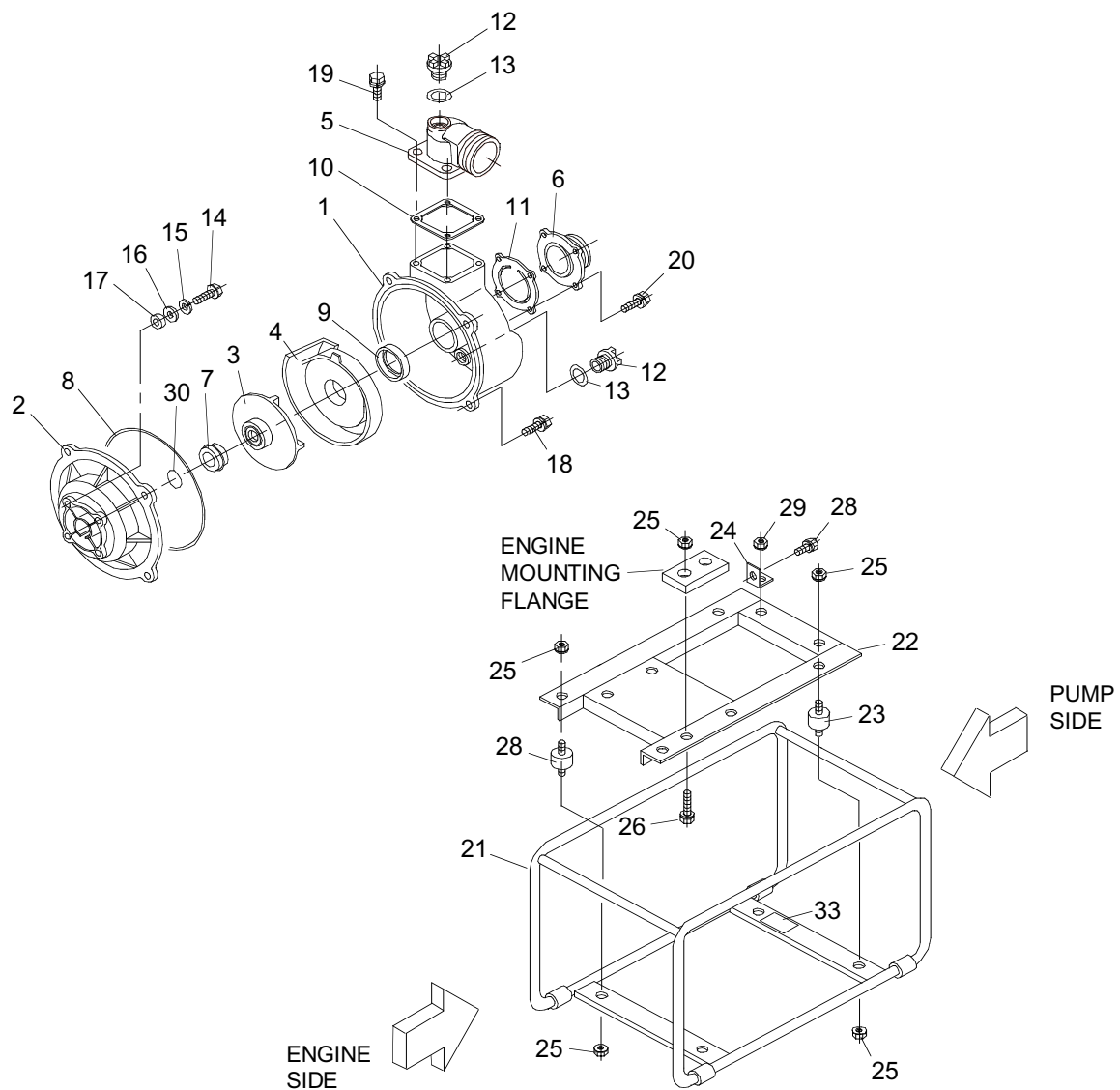

## Parts Listing - Model TE2-100HA Centrifugal Pump

Ref. No.	Part Number	Description	Size	Qty
1	1001-001	Casing		1
2	1001-004	Cover, Casing		1
3	1001-009	Impeller		1
4	1001-011	Casing, Volute		1
5	1001-019A	Bend, Discharge	4- Inch NPT	1
6	1001-013A	Flange, Suction	4- Inch NPT	1
7	1001-010	Seal, Mechanical		1
8	1001-002	O-Ring	209.55 x 3.05	1
9	1001-012	Packing	67 x 86 x10t	1
10	1001-020	Packing	75 x 105 x 2t	1
11	1001-015	Valve, Check		1
12	501-021	Plug *		2
13	501-022	O-Ring *	P-24 (3.5)	2
14	501-005	Bolt, Hex	M8 x 48L	4
15	501-007	Washer, Spring	M8	4
16	501-008	Washer, Plain	M8	4
17	501-006	Seal, Packing	7.8 x 13.5 x 3.3t	4
18	501-003	Bolt, Hex.	M10 x 30 (SW)	4
19	501-003	Bolt, Hex.	M10 x 30 (SW)	4
20	501-003	Bolt, Hex.	M10 x 30 (SW)	4
21	1001-030H	Frame, Cage		1
22	1001-031H	Base		1
23	1001-032	Cushion, Rubber		4
24	1001-034	Bracket		2
25	1001-024	Nut, Spring	M8 (F)	8
26	1001-023	Bolt, Hex	M10 x 45 (SW)	4
27	1001-033	Nut, Flange	M10 (F)	4
28	1001-014	Bolt, Hex.	M10 x 20 (SW)	4
29	1001-033	Nut, Flange	M10	2
30	501-042	Shim		AR
-31	TBD	Crankshaft **		1
-32	GX240 K1WKT2	Engine, Honda ***		1
33	TBD	Nameplate		1

AR = As Required; quantity determined at assembly.

\* Plug (12) includes O-ring (13).

\*\* Crankshaft (-31) has special metric thread. Order Tsurumi replacement crankshaft (-31) (not Honda).

\*\*\* Contact Honda distributor for Honda engine parts.

(-) Items prefixed with a dash are not illustrated.